

INSTRUCTIONS FOR USE AND MAINTENANCE OF JOINERY

1. Transport

- It is recommended to transport the windows in a vertical position on a stand specially adapted for this purpose. The window should be placed directly on a transport strip screwed to the bottom of the window, with the use of appropriate spacers protecting against scratches. The product must be properly protected against damage during transport.
- The stored windows should be placed vertically and properly protected against the influence of weather conditions. The windows shall be stored in dry rooms not exposed to chemical agents.
- The manufacturer recommends removing the foil and protective tape from the profiles and stickers from the glass immediately after the installation. Protective tapes and foils should be immediately removed from the products within 1 month of their exposure to external weather conditions, otherwise the warranty for the purchased products will be lost. External materials used for the assembly (tapes, foams) should be protected against UV radiation and weather conditions within 1 month after the installation of the joinery by the Manufacturer.
- Windows protected by protective foil should not be stored in places exposed to high temperatures and direct weather conditions.
- Transportation/unloading/assembly of glazed joinery using a vacuum suction cup is not recommended. It is recommended that the above steps be carried out after the windows have been disassembled, in which case the glass itself can be transported by means of a suction cup. If it is necessary to transport/unload/assemble the glazed joinery with vacuum suction cups, it is necessary to protect the joinery properly in the place where the sash is connected to the frame and the glass to the sash or frame.

2. Assembly

- Windows shall be installed in such a way that they do not endanger anyone's health and life.
- The product must be properly protected before installation in order to avoid damage and health hazards.
- The installation should be carried out in accordance with the rules of the art of construction, it should be carried out by companies specializing in the installation of windows.
- The windows should be fastened around the perimeter.
- The most common fixing elements used in window installation are mounting screws, dowels, anchors.
- When installing heavy elements protruding from the face of the wall, use specially designed load-bearing brackets or systems dedicated to such solutions (e.g. the Mowo system by Illbruck).
- The choice of fastening method depends on the on-site conditions. The choice of fixing method is made by the assembly company in agreement with the Buyer (if the assembly is not performed by Marsel).
- It is recommended that the elements be glazed by an experienced assembly company, and that special care be taken in the case of self-execution.
- During the installation of windows, the connection between the installed structure and the building is made. The purpose of this connection is to provide the following functions:
 - a. ensure proper thermal and acoustic insulation,
 - b. transfer loads from the structure to the building,
 - c. provide an expansion joint for the mutual deformations of the structure and the building.

3. After installation

- Remove the protective foil from the frames and sashes.
- Fresh plaster and mortar residues should be carefully removed with a sponge soaked in water.
- Use a vacuum cleaner to remove loose plaster, mortar and chips.
- Remove dried plaster and mortar or similar residues with a wooden or plastic spatula.
- After cleaning the element, check all its functions and the correct functioning of the window accessories, such as blinds, electric door openers, self-closing devices, etc.
- Before you start checking the function of a window or door, read through the entire manual.
- It is not recommended to expose the joinery in dark colours to direct influence of factors that may cause their heating. As a result of long exposure to sunlight, profiles can heat up to very high temperatures, which can be as high as 85 °C. and can be deformed.

4. Maintenance

- The joinery user is obliged at least once a year to perform the activities of checking, maintenance, cleaning and adjustment of joinery elements — these activities are not warranty services.
- The hardware should be lubricated at least once a year with technical petroleum jelly or oil for lubricating the hardware. The applied care and cleaning agents must not damage the anti-corrosive coating of the hardware.
- At least twice a year, the screw connections and the stability of the screws fixing the handle must be checked - if necessary, they must be tightened.
- The gaskets should be wiped off at least once a year with technical petroleum jelly or silicone to lubricate the gaskets in order to maintain appropriate properties of the window, e.g. its tightness. The gaskets should also be washed regularly with lukewarm water and dish washing liquid to remove dirt and dust. If the gasket has slipped out of the fixing slot, it can be pushed back into its intended location. Avoid using pointed objects as this may damage the gasket.
- In order to ensure the correct functioning of windows and doors, they must be checked at least once a year for proper function and adjusted if necessary.
- At least twice a year, check the drainage channels for obstructions.
- The window and door profiles should be cleaned with solvent-free and abrasive-free cleaning agents.
- Windows should be protected against contact with hot objects, impregnating agents, adhesives, paints, solvents, dirt, mortar, polyurethane foam, dust.
- Powder and oxide coatings are not resistant to mechanical damage caused by sharp tools and abrasives. These coatings are sensitive to organic solvents, concentrated alcohol, acids, alkalis and petroleum compounds, among other things. Therefore, it is not permitted for the coating to come into contact with these agents. In particular, the protection against contact of coatings with lime, cement and other alkaline building materials must be ensured.
- Maintenance of the bottom frame and guide rail in sliding, lifting and folding doors - all impurities such as dirt, sand, gravel, solids, etc. should be removed by means of a vacuum cleaner from the bottom frame and guide rail. Perform this activity at least once a month. Once a year clean the frame and the guide rail with a cloth.

- The condition for the possibility of using the warranty services is that the User performs the joinery inspection and maintenance activities with the frequency and scope resulting from this manual.

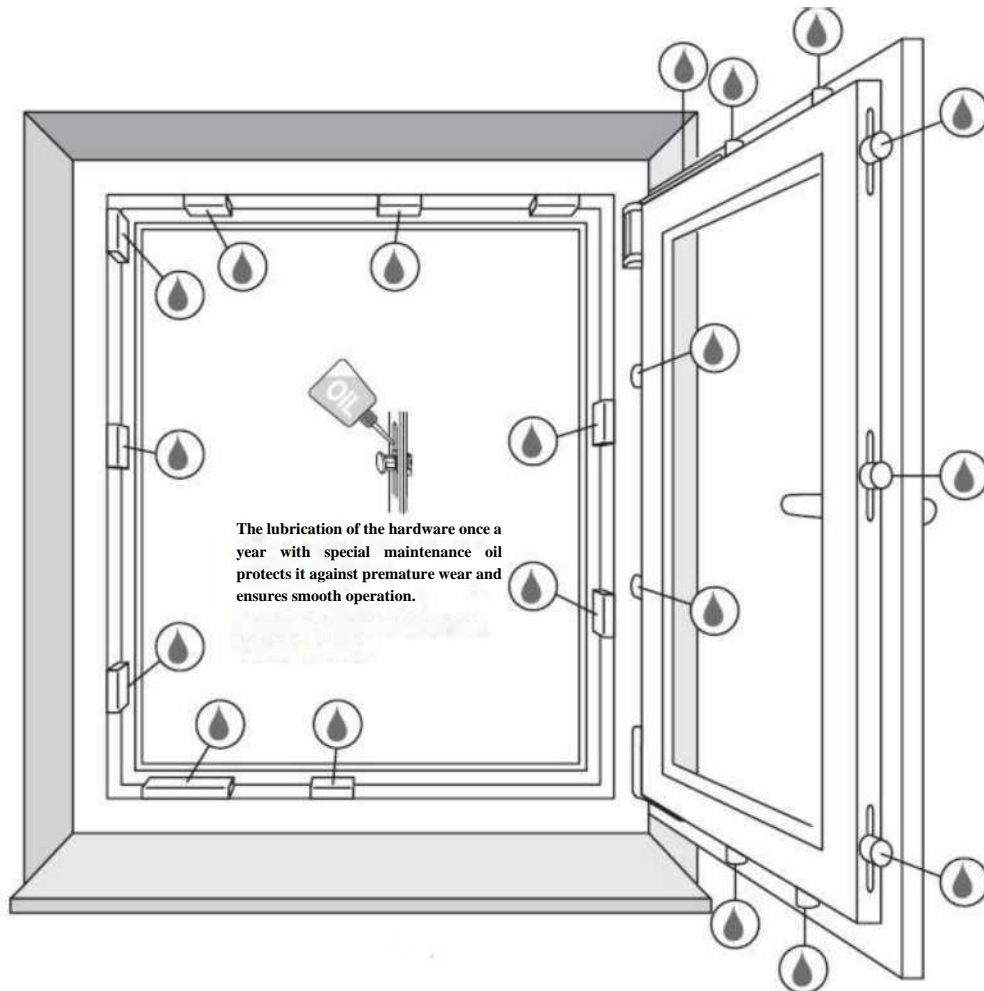

Fig. Lubrication of fittings

5. Method of cleaning

The frequency of cleaning depends on many factors:

- ❖ the geographical location of the building
- ❖ the environment in which the building is located, e.g. marine, industrial, acidic / alkaline, etc.
- ❖ the degree of atmospheric pollution,
- ❖ the wind zone,
- ❖ the degree of protection of the building by neighbouring buildings,
- ❖ the possibility of transferring particles (especially sand) causing erosion of the coating,

- It is recommended to clean the windows with special cleaning agents, not containing abrasive or dissolving agents, any dirt on the windows should be removed immediately.
- PVC and aluminium surfaces can be cleaned with a soft cloth or sponge soaked in mild liquid cleaning agents, free of abrasive powder and suitable for the surface.
- The use of aggressive chemicals is not permitted.
- Do not use sharp tools to clean frames, sashes and windows, as they may cause permanent and indelible scratches.
- Glass panes should be cleaned with commonly used cleaning agents, which do not contain ammonia or other aggressive substances.
- Do not use pressure washers or sharp brushes / sponges for cleaning.
- Dust accumulating between the door frame and the gasket must be removed by means of a vacuum cleaner equipped with a nozzle suitable for cleaning this type of surface.
- Clogged drain holes can be cleaned with a vacuum cleaner. Do this every 6 months and shorten this period if necessary.
- The profiles should be cleaned at least twice a year.
- The recommended method of cleaning painted surfaces is regular washing with a mild detergent solution (e.g. 5% dish washing liquid) in warm water. All surfaces should be cleaned with a soft sponge or cloth. Do not use harder brushes than natural bristles (glass washing can be done simultaneously for convenience). After washing, rinse the surface thoroughly with clean water.
- Anodized surfaces may be polished after washing and rinsing with a dry, delicate cloth to restore shine.
- If atmospheric pollution has caused stains that are difficult to remove, extraction gasoline is recommended to remove them from painted surfaces. In this case abrasives (sandpaper, polishing pastes) and solvents containing ketones, esters or alcohols must not be used.
- Use clean water for cleaning. Washing can be more effective if you use a cloth that does not scratch surfaces on a decorative surface.
- During washing, the temperature of the coating must not exceed 25 °C.
- The temperature of the washing water must not exceed 25 °C. The coating must not be washed with a steam jet.
- Before cleaning the surface, check the effect of the cleaning agents used. The test is to be carried out on hidden surfaces. In case of undesired effects, do not give up on using a tested cleaning agent.
- Under no circumstances should cleaning agents below 5pH or above 8pH be used.
- Do not use highly acidic or alkaline cleaning agents (including those containing detergents) or surfactants that may react with aluminium.

- Do not use abrasive cleaning agents or clean the surface by friction. Delicate cotton fabrics intended for industrial cleaning may be used. When wiping, do not press the fabric too hard against the surface to be cleaned.
- Do not use organic solvents containing esters, ketones, alcohols, aromatic compounds, glycol esters, chlorinated hydrocarbons, etc.
- Do not use detergents of unknown origin.
- Do not use salt or chemicals to remove ice in the vicinity of the profiles.
- The maximum exposure time of the cleaner must not exceed one hour. If necessary, the washing process can be repeated after 24 hours.
- After each wash, the surface must be immediately rinsed with clean water.
- Regular cleaning prevents the formation of intense, very difficult to remove dirt. For outdoor applications where a decorative appearance and protective function are particularly important, e.g. gantries, entrances, shop facades, etc., weekly cleaning is recommended. In this case, it is possible to use water and chamois leather (suede) for cleaning, then wipe the elements from the top to the bottom with a soft, dry cloth.
- Window frames and sashes, window sills and facades must be cleaned regularly. The frequency depends on the aggressiveness of the environment.
- In addition to cleaning and maintenance, windows and doors should be inspected annually to extend their service life and to maintain the comfort of operation at a constant level. Inspections are not included in the scope of warranty services.

6. Operation

Operating windows

The condition for the proper functioning of windows is to comply with the rules concerning their use, among which the basic ones are:

- a) a change of the handle position should take place after pressing the sash against the frame
 - putting the handle in the vertical position downwards - "window closed"
 - putting the handle in the horizontal position - "window open"
 - putting the handle in the intermediate position - "window unsealed"
 - putting the handle in the vertical position upwards - "window tilted"

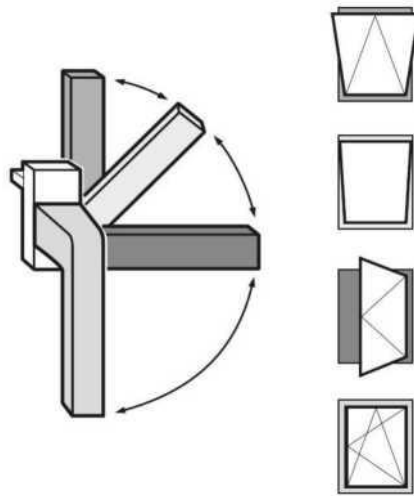

Fig. Function of the window depending on the position of the handle for basic hardware diagrams.

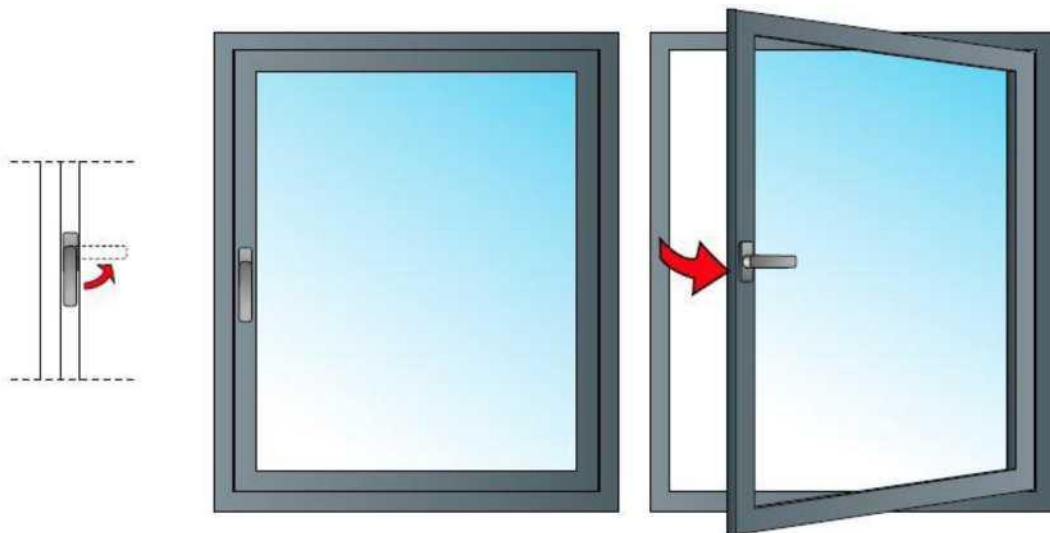

Fig. Turn-Only window

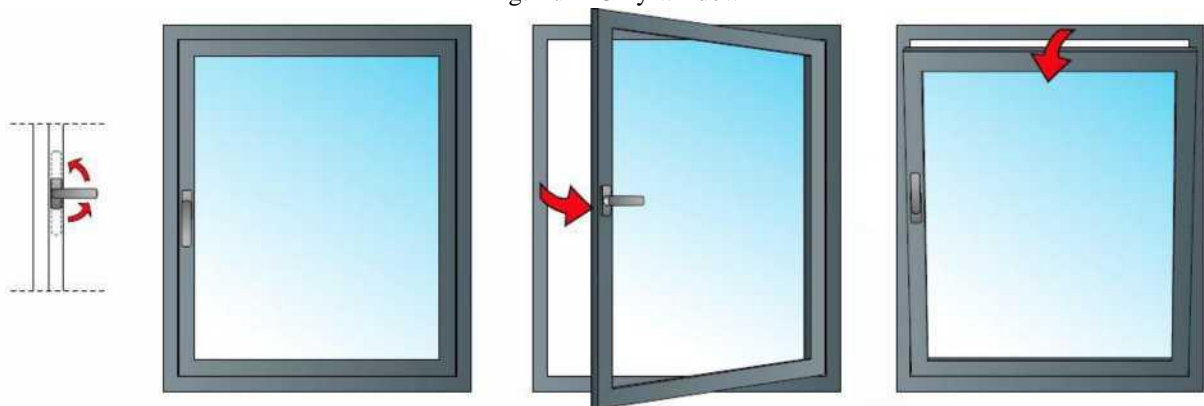

Fig. Tilt & Turn window



Fig. Tilt window with side handle

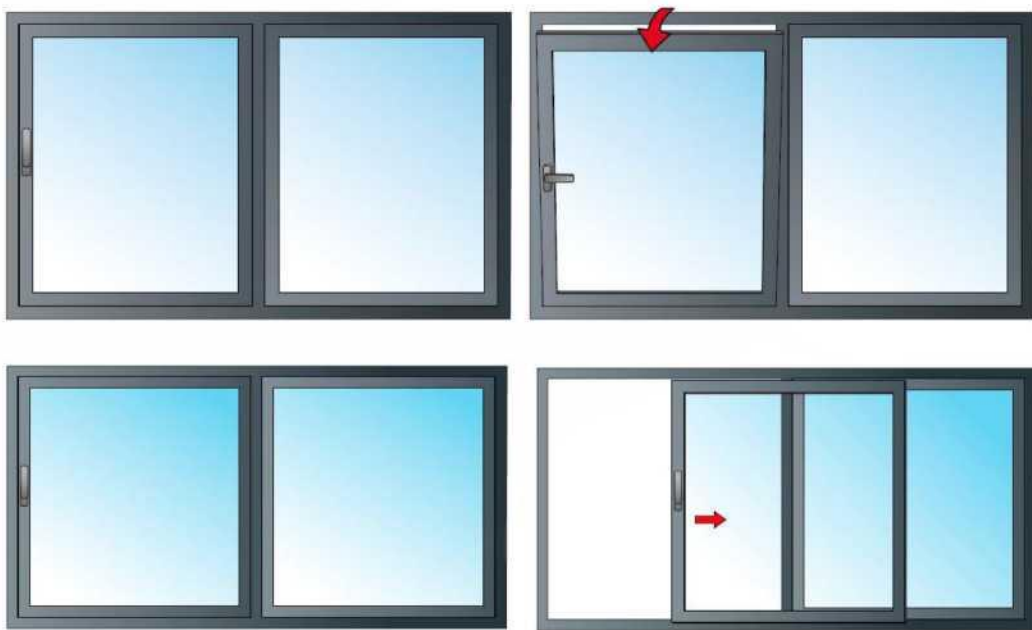

Fig. Tilt and slide door (PSK)

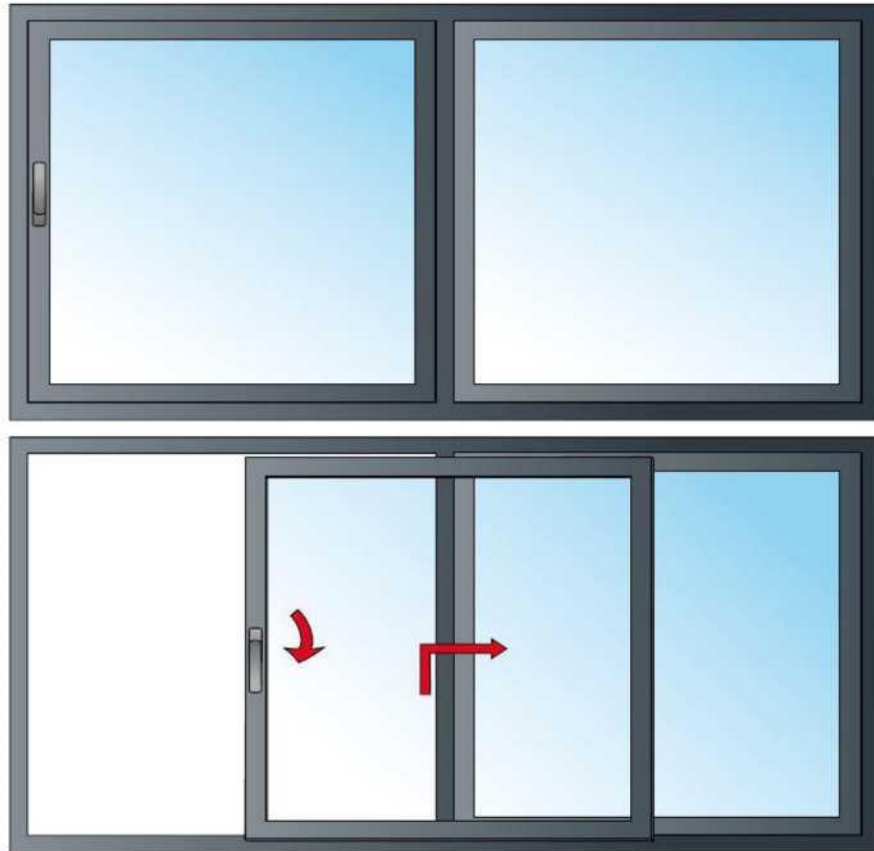
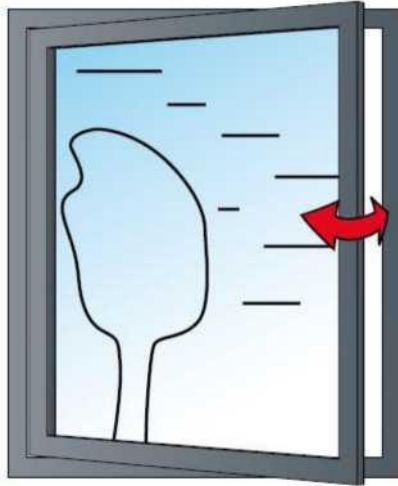

Fig. Lift-and-slide door (HST)

- b) the use of windows should be in accordance with their intended use
- c) Do not put your hand between the sash and frame and do not block windows by placing objects between the sash and frame.



- d) if the screws of the handle, hinges or lock come loose, they must be tightened immediately
- e) windows must not be left open in the event of strong winds or draughts in rooms



- f) do not leave windows open when there are children in the room



- g) do not turn the handle when the sash is open or tilted

h) no additional load shall be placed on the sash

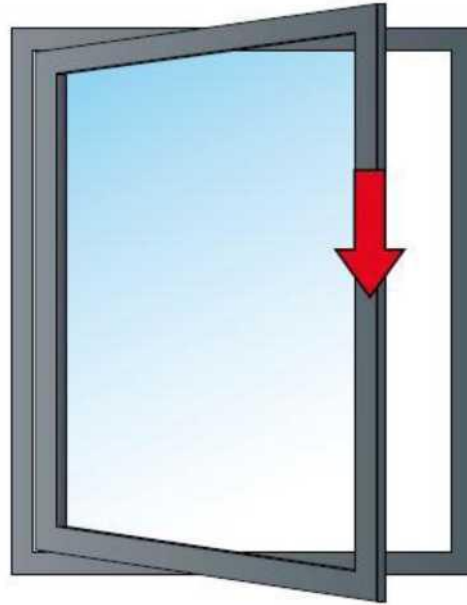

i) do not press the sash against the jamb

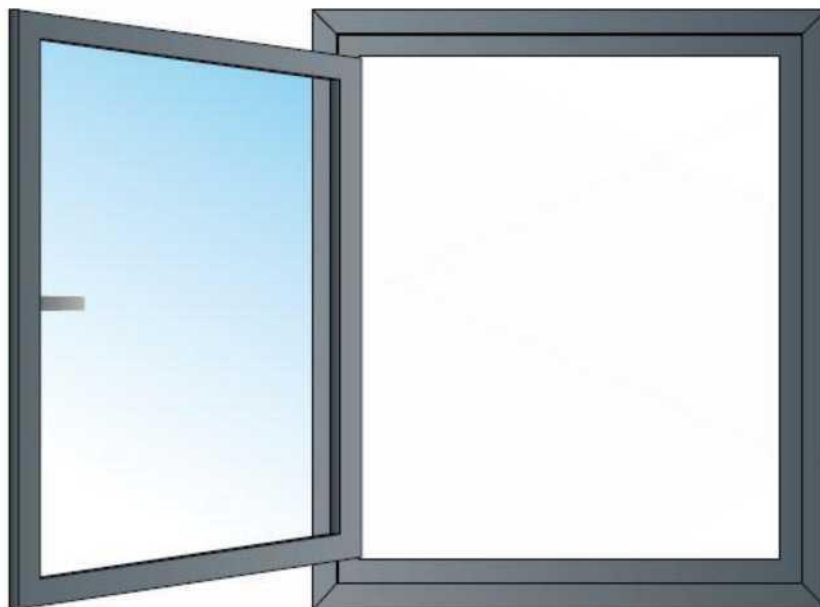

Operation and adjustment of WinkHaus hardware

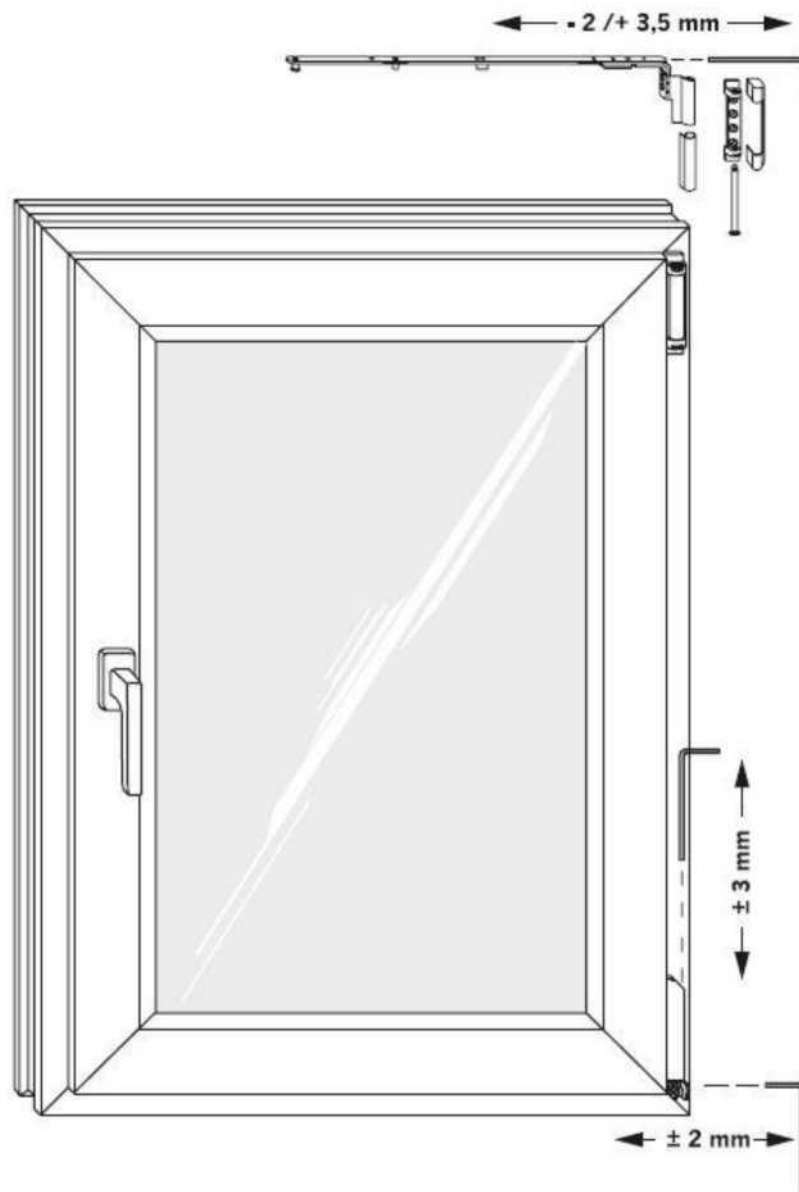

Fig. Adjustment of WinkHaus activPilot Concept hardware

Adjustment of the pressure

The octagonal locking mushroom allows the sash pressure to the frame to be adjusted with a special key (active HV 11, cut-out 7,8). In this way you can decrease

the pressure in summer and increase in winter.

The adjustment is made on the open side.

the window.

Fig. Adjustment of sash pressure

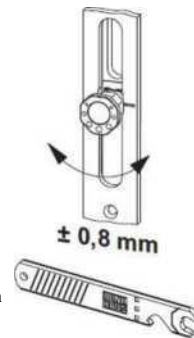

Octagonal mushroom

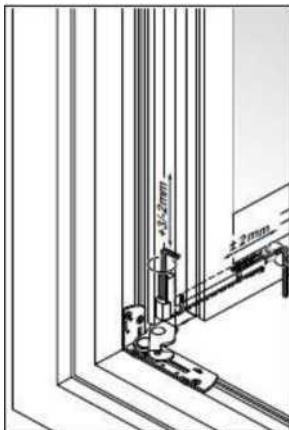

Frame hinge (up to 100 kg)
- height adjustment +3mm/-2mm
- side adjustment of the sash +/- 2 mm

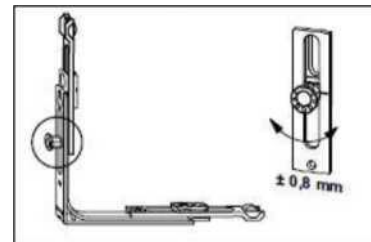

- adjustment of the sash pressure to the frame by turning the octagonal mushroom (+/-0.8 mm)

Note! Adjustments can only be made when the hardware is in the open position.

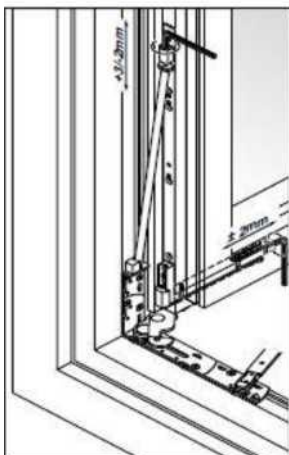

Frame hinge (100 kg)
- height adjustment +3mm/-2mm
- side adjustment of the sash +/- 2 mm

Note! Remove the sash hinge adjustment screw (see Fitting the sash in the frame)

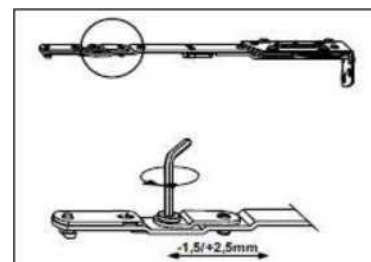

- side adjustment of the sash:
2.5 mm to the hinge, 1.5 mm from the hinge



Note! The hardware can be adjusted only by qualified personnel!

Fig. Adjustment of WinkHaus activPilot Select hardware

**Suspending the sash
on the frame and removing it**

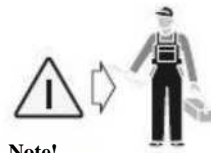

Note!
Sash removal and
installation
in the frame can only
be performed by
qualified personnel!

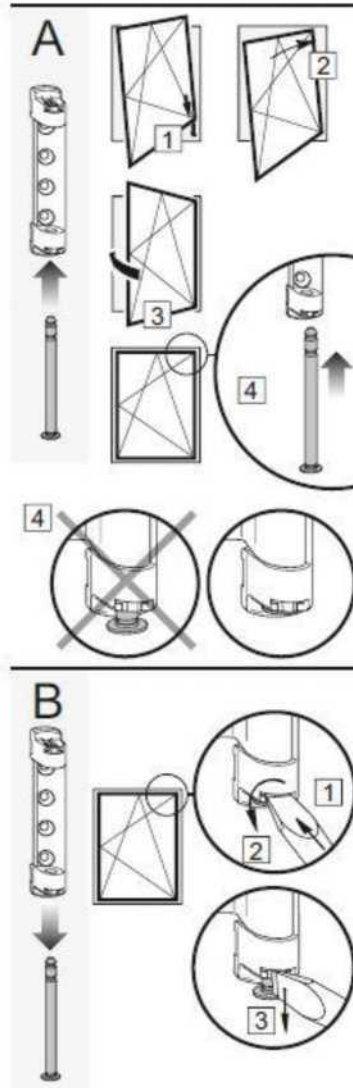

Note! When inserting and removing the locking device hinge pin
the sash should be closed.

Fig. Suspension and removal of the window sash on the activPilot Concept hardware

Suspension of the sash on the frame hinge

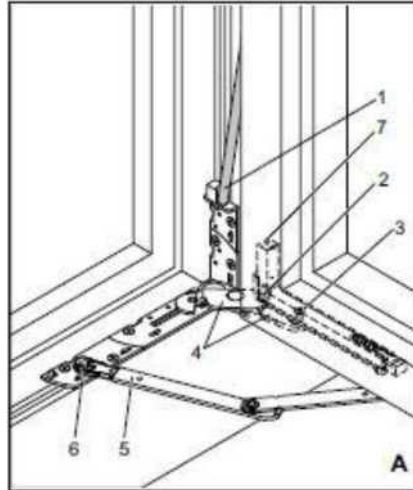

1. Switch off the handle rotation lock, if installed).
2. Turn the handle to the "tilt" position.
3. If a sash hinge rail (version 150 kg) is used, remove and/or set the height adjustment screw (7) from the sash hinge to a minimum position before suspending the sash.
4. Swivel the arms (4) of the hinge up to 90°.
5. Insert the rail (1) into the adapter (if installed - version 150 kg).
6. Suspend the sash with the embedded rail on the hinge arms (4):
 - place the pin (2) in the position marked on the drawing,
 - at the same time insert the pin (3) into the groove of the hinge.
7. Opening limiter (if installed):
 - connect the stop arm (5) to the adapter pin (6). The click sound accompanies the correct connection of these two elements.

Fig. Suspension of the window sash on the frame hinge on the activPilot Select hardware

Suspension of the sash on the locking device

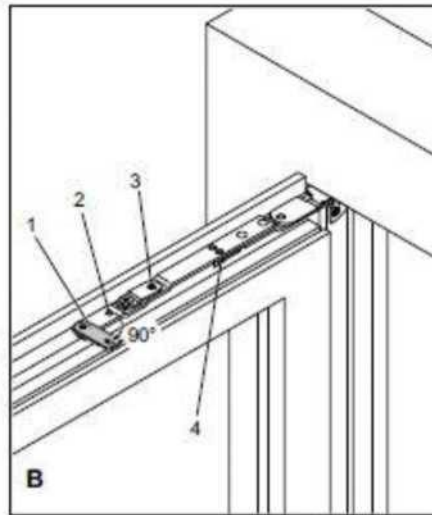

1. **Unlock the locking device:**
 - press the safety spring (2) with a screwdriver and simultaneously turn the locking device lock (1) by 90°.
2. **Open the locking device up to 90° and fit with the locking device arm's pins (4).**
3. **Push the locking device pin (3) into the hole on the counter element.**
4. **Push the pins into the longitudinal opening of the locking device arm.**
5. **Turn the locking device lock (1) to the initial position so that the safety spring acts.**
6. **Use the handle to turn the hardware into a open out position.**
7. **Switch on the handle rotation lock (if installed and disengaged during the preparation of the sash for installation).**
8. **Then check the connection of the locking device with the locking device arm and the sash hinge with the frame hinge.**
9. **Close the window**

Fig. Suspension of the window sash on the locking device on the activPilot Select hardware

Locking device and frame hinge

The interfaces of the elements (shown in the picture) should be lubricated once a year with a special fitting oil.

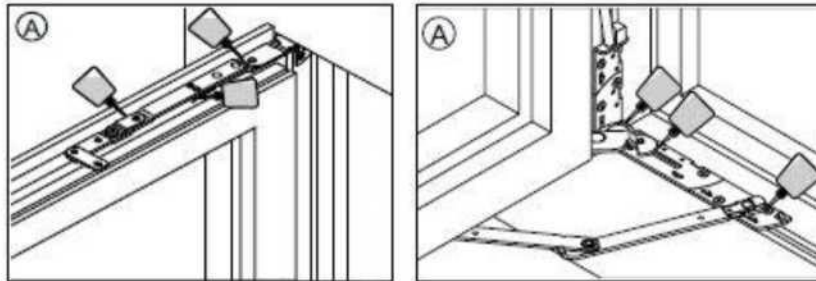

Frame strikers

Use suitable grease to maintain the strikers on the working edges. Lubricate the working surfaces of the octagonal mushrooms with oil free of resins and acids.

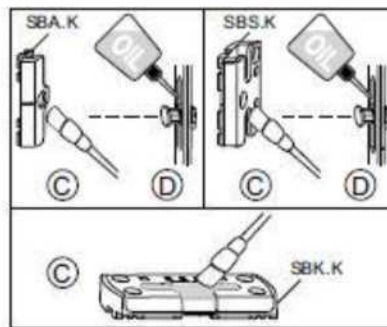

Fig. Maintenance of the activPilot Select hardware

Adjustment of door hinges

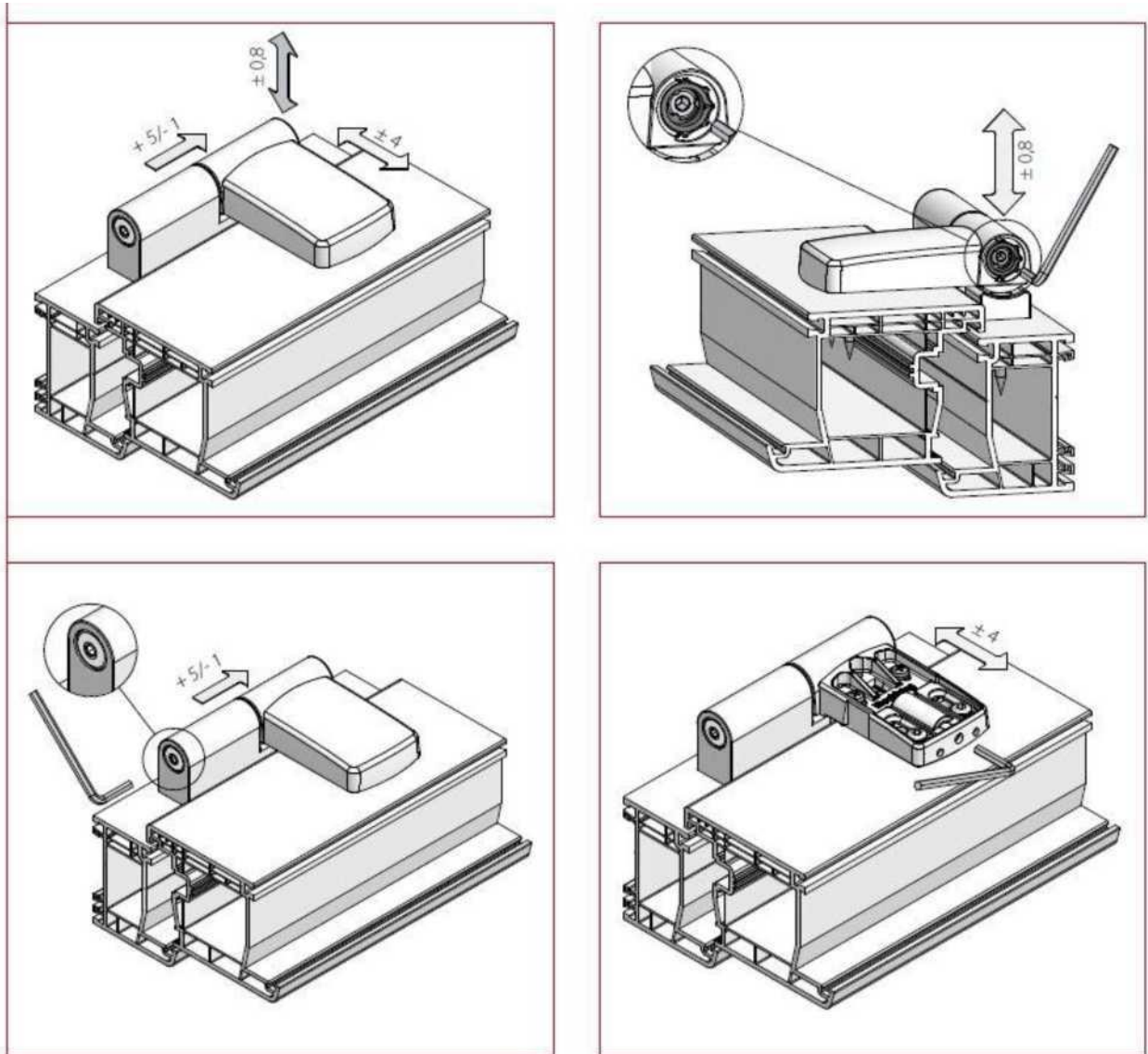

Fig. Adjustment of the Mtec door hinges

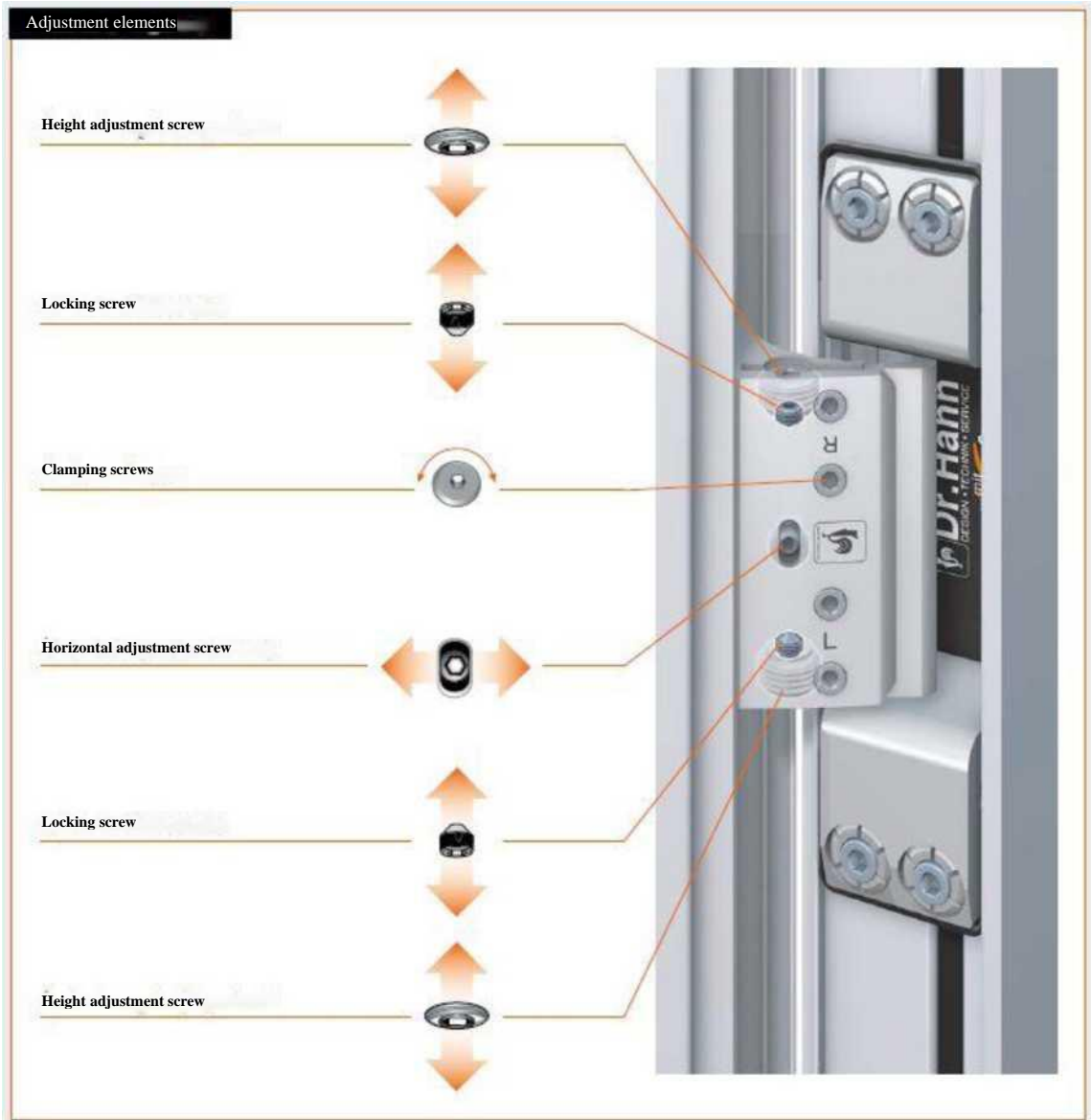

Fig. Adjustment of concealed door hinges Dr Hahn

Horizontal adjustment

Horizontal adjustment ± 2 mm (as required on top and/or bottom hinge). Loosen the clamping screws slightly.

Unscrew the two retaining screws as far as they will go.

Set the size of the gap between the sash and frame.

Tighten both retaining screws.

Tighten the clamping screws with 1.5 to 2 Nm

Note: tightening them too much leads to

Fig. Horizontal adjustment of concealed door hinges Dr Hahn



Fig. Vertical adjustment of concealed door hinges Dr Hahn

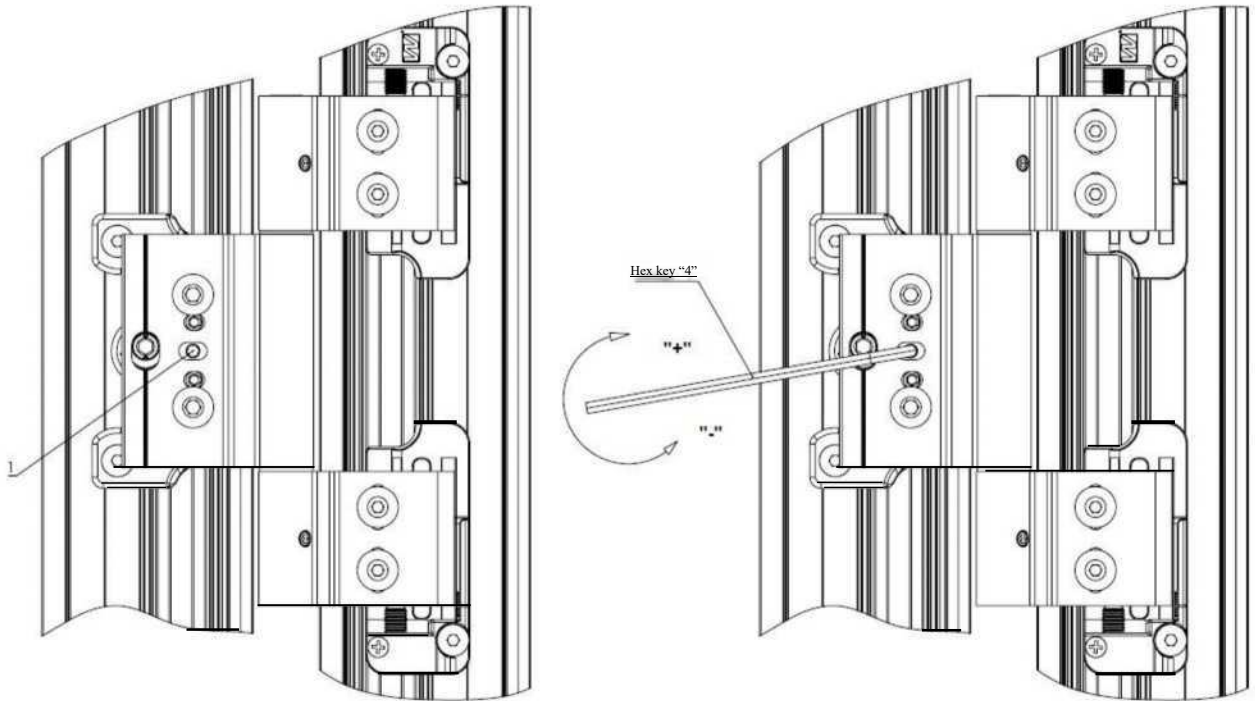

ADJUSTMENT OF THE GAP: (adjustment scope $\pm 2.5\text{mm}^*$)

1. Adjust with the set screw; one turn of the key (360 degrees) corresponds to a 1.25 mm gap change.

* for systems with 6mm system gap, for 5mm gap due to the thickness of the plate, the possible adjustment value is +2.5mm

-1.5mm,

ROLL HINGE WR
GAP ADJUSTMENT (LEFT/RIGHT)

Fig. Horizontal adjustment of roller door hinges (WR) Wala

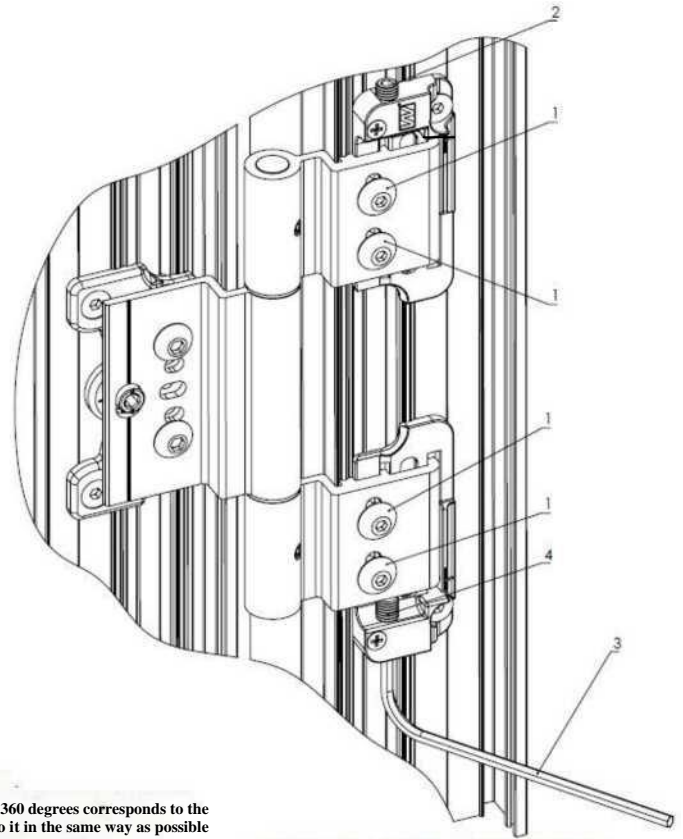

HEIGHT ADJUSTMENT: (adjustment scope ±5mm)

1. Loosen the screws 1 for each hinge in the door.
2. Unscrew the top screw 2 for each hinge in the door
- 3 If the door is very heavy, we recommend to preload it with e.g. wedges.
4. Use a hex key 3 to make the adjustment by means of the screw 4 (one rotation by 360 degrees corresponds to the change of height by 1.25 mm) Do it for each hinge in turn in the door trying to do it in the same way as possible
5. After adjustment, tighten the screws 1 on all hinges.

ROLLHINGE WR
HEIGHT ADJUSTMENT

Fig. Vertical adjustment of roller door hinges (WR) Wala

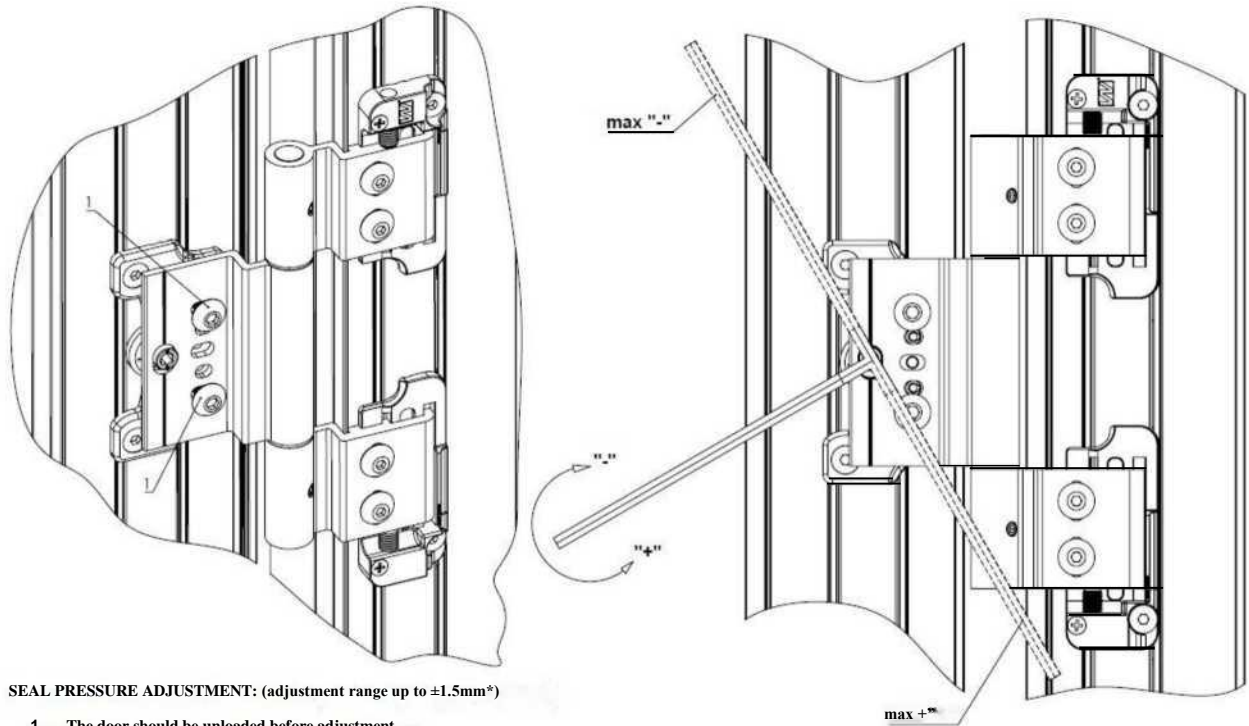

SEAL PRESSURE ADJUSTMENT: (adjustment range up to $\pm 1.5\text{mm}^*$)

1. The door should be unloaded before adjustment.
2. Lightly loosen the screws 1.
3. Adjust the pressure of the seal with an eccentric by using a hex key "5". The maximum adjustment is achieved by turning by 1/4 turn (90 degrees).
4. After adjustment, tighten the screws 1

* the actual range may be smaller because of the value of the gap at the seal depending on the aluminium system

ROLL HINGE WR
SEAL PRESSURE ADJUSTMENT

Fig. Adjustment of pressure of roller door hinges (WR) Wala

Sash and frame gap width adjustment

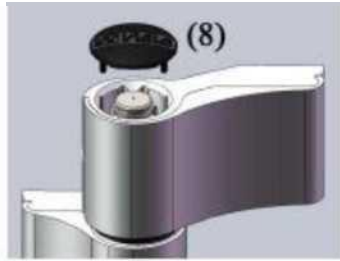

Remove the cap(8), (e.g. by prying it off with a flat screwdriver).

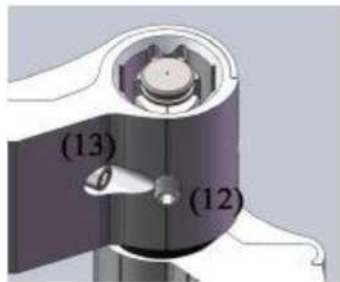

With the open door, loosen the M4 screw [13] locking the cover and loosen the set screw M6x5 (12).

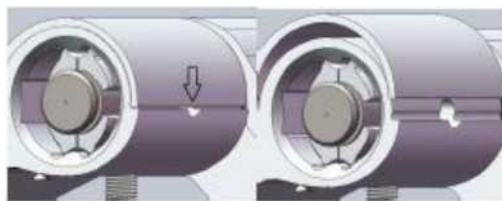

Using the process opening lift the cover with a flat screwdriver to gain access to the adjustment.

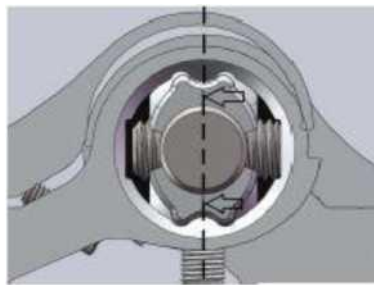

The hinge is in the "0" position when the markers are in a straight line (aligned with a hypothetical axis).

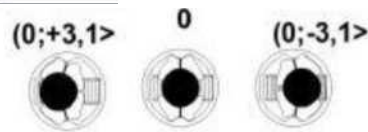

Adjustment scope

After the adjustment:

- tighten the set screw M6x5(12),
- install the cover
- tighten the screw M4 (13)
- install the cap (8)

Fig. Horizontal adjustment of double-plate door hinges (WR) Wala

VERTICAL adjustment:

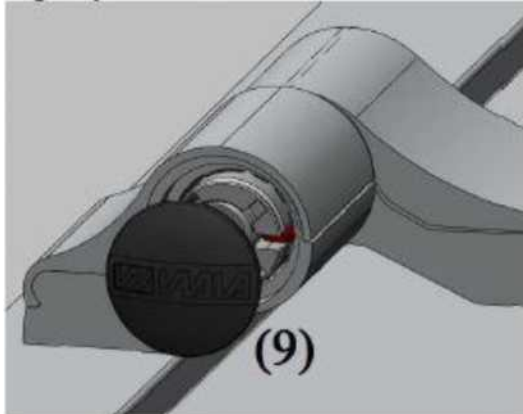

Remove the cap(9), (e.g. by prying it off with a flat screwdriver).

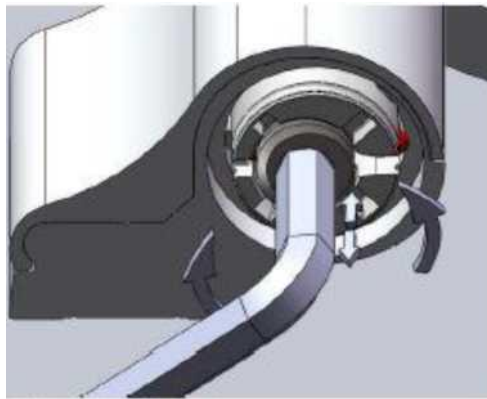

By tightening the set screw M12, smooth vertical adjustment (+ 4 mm] is made.

After the adjustment

- tighten the set screw M6x5 (10)
- install the cap (9)

Fig. Vertical adjustment of double-plate door hinges (WR) Wala



After the adjustment:

- screw in the M12 pressure screw [until it resists slightly],
- tighten the set screw M6x5 (10)
- install the cap (9)

Fig. Adjustment of pressure of double-plate door hinges (WX) Wala

Sash and frame gap width adjustment

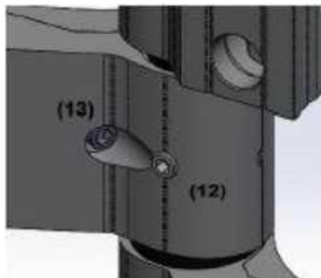

With the open door, loosen the M4 screw (13) locking the cover and loosen the set screw M6x5 (12).

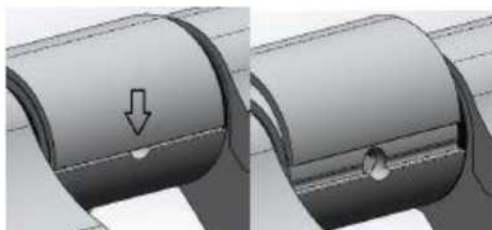

Using the process opening lift the cover with a flat screwdriver to gain access to the adjustment opening. The adjustment is done by turning the adjusting screw

The adjustment scope is ± 3.1 mm

After the adjustment:

- tighten the set screw M6x5(12),
- press the cover
- tighten the screw M4 (13)

Fig. Horizontal adjustment of triple-plate door hinges (WR) Wala

VERTICAL adjustment:

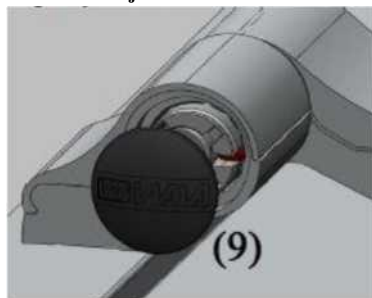

Remove the lower cap (9), (e.g. by prying it off with a flat screwdriver).

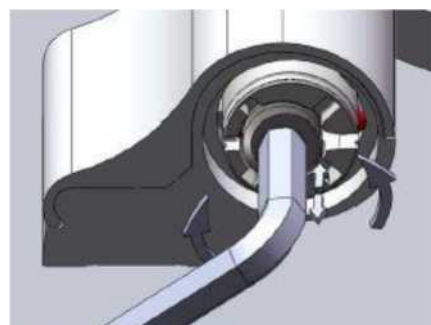

By tightening the set screw M12, smooth vertical adjustment [+ 4mm] is made.

After the adjustment
- install the lower cap (9)

Fig. Vertical adjustment of triple-plate door hinges (WR) Wala

Hinge adjustment:





Seal pressure adjustment:		
	Remove the caps (9), (e.g. by prying it off with a flat with a flat screwdriver)	
	With the open door, loosen the set screw M6x5 (10) in the upper and lower sash	
	Completely unscrew the set screw M12 in both plates (lower and upper).	
	Embed:	
		"WALA" KEY
		"LOB" KEY
		WASHER OR RING 4.30
		Flat screwdriver width 15 mm

Fig. Adjustment of pressure of triple-plate door hinges (WR) Wala

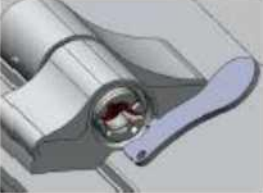
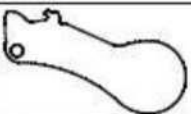
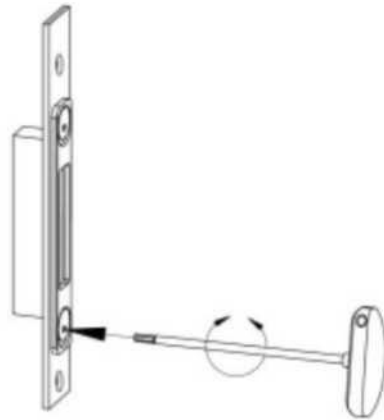

Fig. Adjustment of the door striking plate

electric door strike

BIRA

WITH MECHANICAL SWITCH



Mechanical switch in the electric door strike

A mechanical switch disconnects the electrical control of the electrical door strike, allowing the door to remain open regardless of electrical impulses, until the switch is switched on again. The electrical door strike with a mechanical switch is often referred to as a day-night door strike.

The mechanical switch must not be used in fire door electrical door strike. Examples of using a mechanical switch:

- In the office when for a specified period of time we want to allow free passage for office users without requiring them to use card readers/codes. The electric door strike does not require any power supply to remain unlocked. Please note that the access control system does not record any passages in this case.
- In a public place - this function is particularly useful in situations where there are many users at specific times, who do not have access cards/codes or who are not required to use access cards. This function is usually used during business hours.
- In a house/apartment block - when a resident wants to use the door/wicket several times in a row (shopping, moving, renovating, etc.) at short intervals, without the need to enter a code or use a key at each passage.

Fig. Electric door strike with day/night function

Operation of door closers GEZE

Installation tips:

- ❖ The installation must be carried out by a qualified person.
- ❖ The installation must be carried out in accordance with the enclosed instructions, mounting template, drawings and the following guidelines.
- ❖ If necessary, the door shall be provided with an additional door stop to limit the opening angle of the door.
- ❖ The possible opening angle of the door is strictly dependent on its type and geometric parameters.
- ❖ The proper function of the door closer depends on the type of installation and the size of the door.
- ❖ The closing force of the door closer on fire and smoke protection doors shall be set to not less than “3”.
- ❖ Do not use mechanical opening lock devices on fire and smoke protection doors.

> Slipping the door closer cover

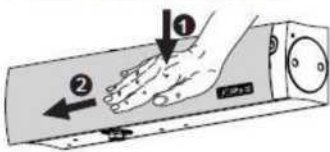

> Installation of the door closer cover

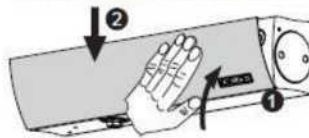

> Adjustment

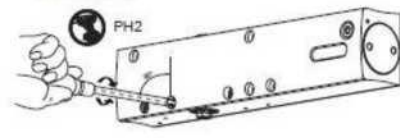

GEZE TS 5000

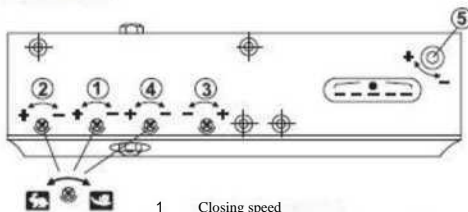

- 1 Closing speed
- 2 Final closing phase - driving in
- 3 Opening suppression
- 4 Closing delay (only in TS 5000 S)
- 5 Door closer closing force value

Door closer closing force value	Door leaf width [mm]
2	to 850
3	850-950
4	950-1100
5	1100-1250
6	1250-1400



Smoothly running doors must be closed by a door closer!

GEZE TS 4000

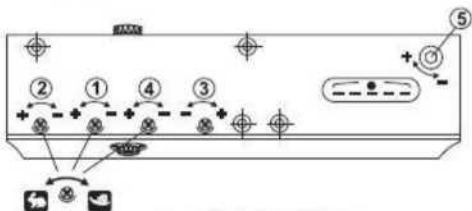

- 1 Closing speed
- 2 Final closing phase - driving in (only in TS 4000 S)
- 3 Opening suppression
- 4 Closing delay (only in TS 4000 S)
- 5 Door closer closing force value

Door closer closing force value	Door leaf width [mm]
1	to 750
2	750-850
3	850-950
4	950-1100
5	1100-1250
6	1250-1400



Smoothly running doors must be locked by the door closer!

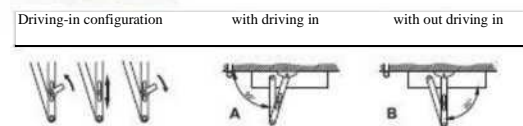

! Adjustment of the final closing phase (driving in) by changing the arm length

! In the case of installation with slide rail, the permissible width of the

Fig. Adjustment of GEZE door closers

GEZETS 3000 V / GEZE TS 3000 EN3

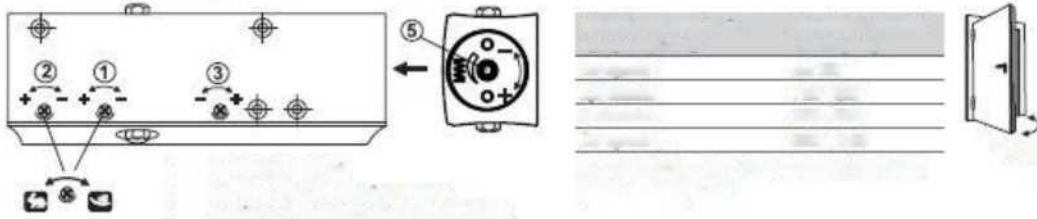

GEZE TS 2000 V

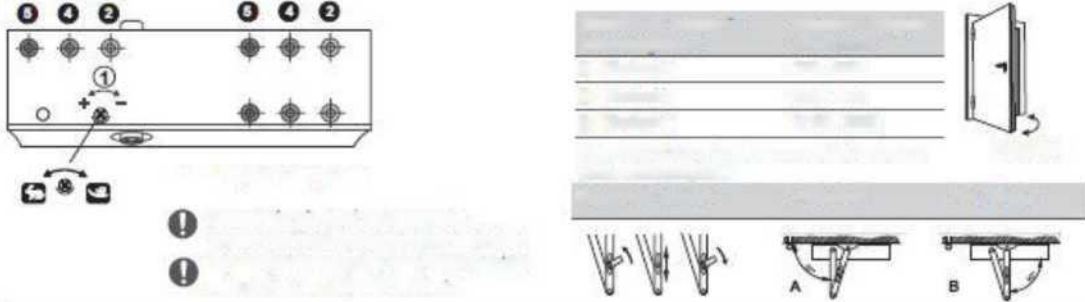

GEZE TS 2000 V BC

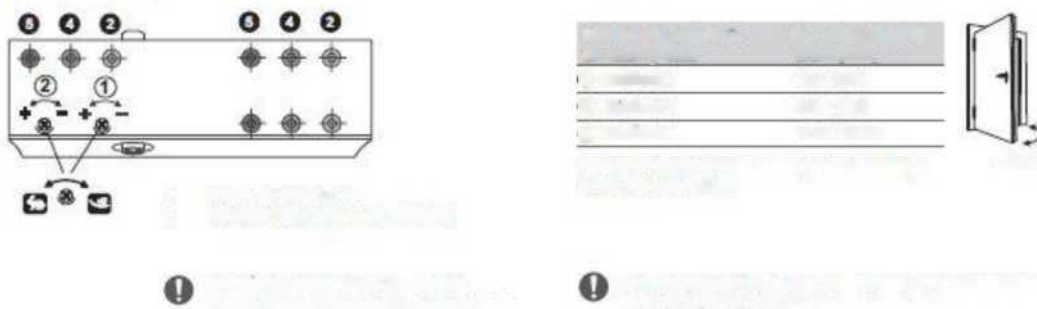

GEZE TS 2000 NV

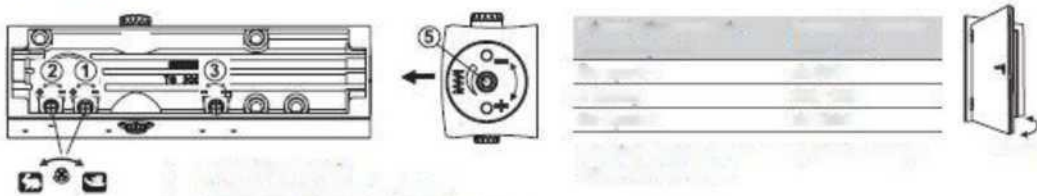

Fig. Adjustment of GEZE door closers

Scissor arm with a lock

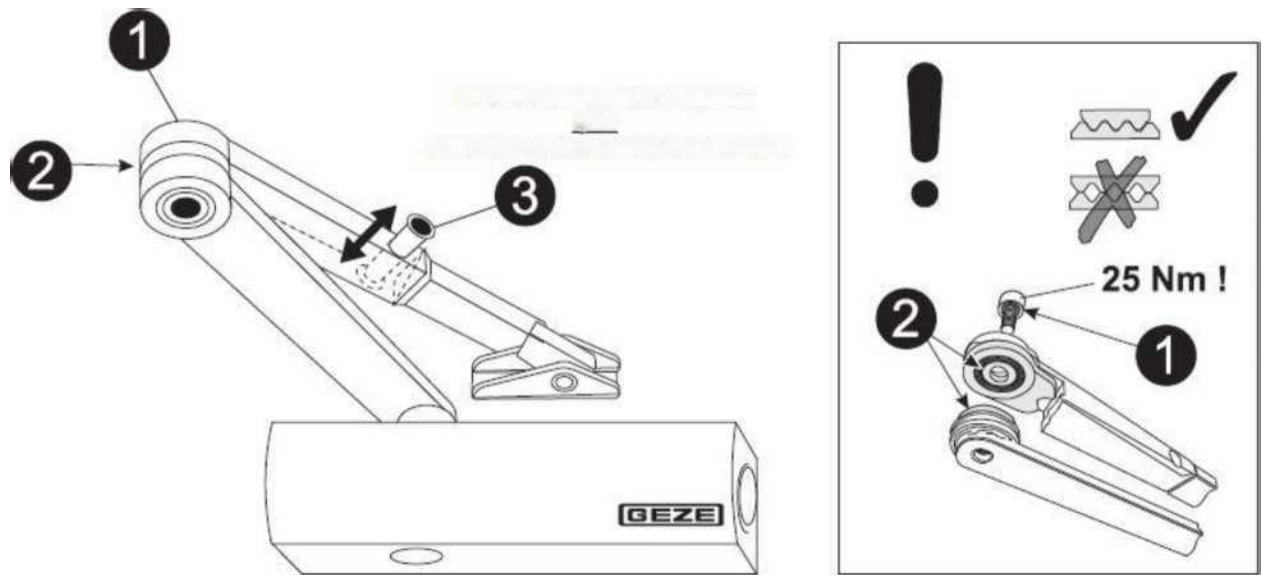

Fig. Operation of the arm with a GEZE lock

Scope of periodic maintenance of the door closer:

- ❖ Check for oil leaks from the door closer body.
- ❖ Check the tightening torque and the tightening of the screws securing the door closer body, rail or arm and the screw connecting the body to the rail or arm.
- ❖ Check the wear of sliding elements (cube, rail) and possible replacement (does not apply to door closers with scissor arm).
- ❖ Check the condition of the arm joint and the opening lock.
- ❖ Adjust the door closer parameters related to speed and closing force.
- ❖ Lubricate the arm joint (does not apply to rail door closers).
- ❖ Check and adjust the closing sequence mechanism (applies to the version for double-leaf doors with mechanical closing sequence adjustment).
- ❖ Check the electrical connections, check the condition of the wiring, release buttons in the electromagnetic interlocks (applies to the version with electromechanical interlocking opening position).

Operation of Portos roller shutters

The external blind and its components are designed in such a way that they are not permanently deformed during proper use.

Observe the manufacturer's instructions for use.

The outside blind can be used at temperatures from -25 °C to +45 °C.

Do not use the external blind in the event of icing on the shield.

Continuous operation of the external blind equipped with an electric motor should not exceed 4 minutes.

When operating the shutter, there must be no objects or persons within the working range of the shutter, i.e. directly underneath the shutter. When the shutter is fully opened, the bottom slat with the gasket should always be in the side guides. To close and open the external blind are used: electromechanical drives, which can be equipped with an emergency opening mechanism (a crank with a hook supplied with the blind - it is used only for emergency opening - it is not allowed to use the crank as the primary drive), manual drives such as tape, cord, cardan mechanism with a crank, a spring to roll up the external blind curtain.

In order to avoid the possibility of the curtain blocking during lowering (e.g. after the construction of the house), it is necessary to eliminate dirt from the brush gaskets located in the side guides of the external blinds and from the shield itself. The blinds user should, for example, perform a full cycle of opening and closing the external blinds at least 8 times a month.

Inspection and maintenance work should be carried out at least every 3 months in accordance with this manual.

The basic maintenance can be carried out by the user without any special rights. This involves removing sand particles and other contaminants from the curtain and the interior of the guide rails, which can lead to scratches on the elements of the blind, as well as visual inspection of the overall condition of the blind, and inspection of the completeness, condition and effectiveness of all components. For external blinds equipped with roller mosquito nets, the chambers guiding the mosquito net in the side guides should be cleaned at least once a month. Failure to follow the guidelines may cause the mosquito net to close incorrectly in the lower position and slow down the work of lifting the mosquito net when it is fully unlocked. The following rules should be observed during maintenance operations:

1. Maintenance work must be carried out when the external blind is immobilized - in this case it is best to disconnect the power supply during maintenance.
2. Do not use sharp or rough tools for cleaning the blinds.
3. Wash the surface of the blind with lukewarm water using mild neutral detergents, preferably at the lowest temperature of +10 °C.

CAUTION - detergents and corrosive substances may damage or discolour the paint film.

Any damages caused by special weather conditions or natural wear and tear is not subject to complaint.

It is considered natural that the curtain's paint coating is worn out, in which minor scratches may occur after about 300 cycles of normal use.

In case of self-treatment of the electric roller blind, it is necessary to adjust the limit switches and possible correction of the number of feathers in the armouring.

END POSITION ADJUSTMENT

Limit switch adjustment must be carried out when the motor is cold. Adjusting the terminals requires several starts of the motor, which gets hot during operation. The tubular motor has a thermal breaker that interrupts the motor when it reaches a certain temperature. The timer of constant motor operation is 4 minutes. After this time the motor switch off until it has cooled down, e.g. for. 30 minutes.

ADJUSTMENT OF THE SHILED TOP POSITION

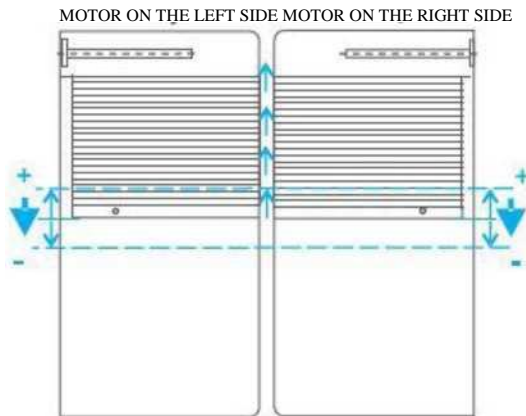

The limit switches are located in the motor head. Each of them is marked with an arrow indicating the direction of rotation of the motor.

The down arrow indicates the direction of the motor causing the roller blind shield to be lifted. So with this tip you should adjust the top end position of the roller blind.

ADJUSTMENT OF THE SHIELD BOTTOM POSITION

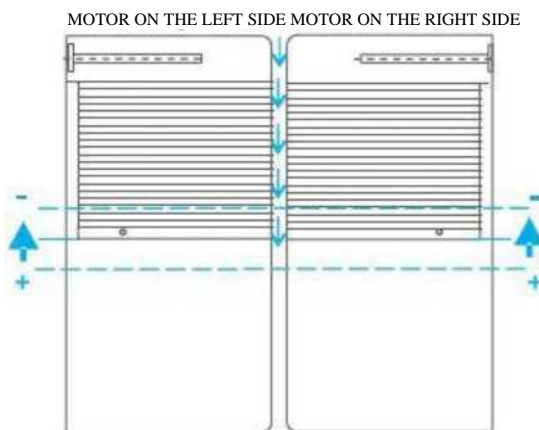

The up arrow indicates the direction of the motor causing the roller blind shield to be lowered. The knobs located next to it are user for the adjustment of the bottom end position of the roller blind.

Turn the key in the adjustment seat in the direction of "plus". (+) to increase the operating range of the motor in a given direction.

Turn the key in the opposite direction to reduce the motor's range of operation in the given direction.

Fig. Adjustment of the end position of the roller shutter

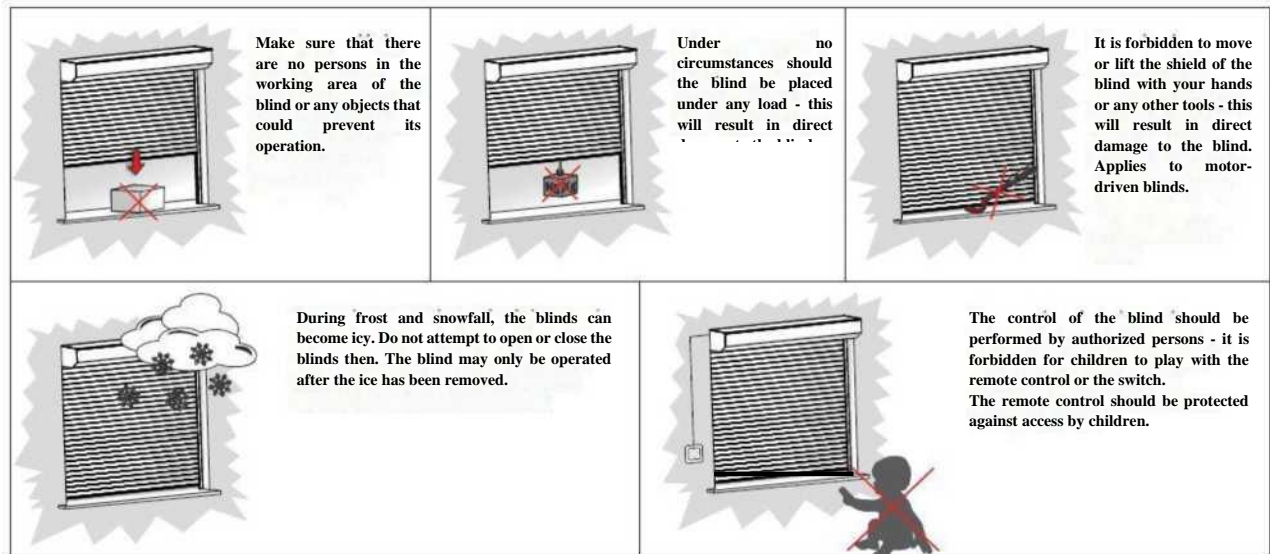

Fig. Recommendations and reservations regarding the operation of Portos roller shutters

Operation of façade blinds

1. Crank drive with cardan joint.

The operation of the crank lift mechanism requires special care and intuition, as the gearbox used allows high forces to be applied, which can lead to damage to the elements of the façade blinds. Therefore, stop cranking when you feel resistance or notice that the armour of the blind has stopped during lifting or lowering. In façade blinds, turning the crank clockwise raises the shutter shield, while turning the crank counterclockwise lowers the shutter shell.

2. Motor drive and Somfy remote control.

Press the remote control/switch key with the corresponding blinds movement direction (up/down). At this point the blind will start to raise or lower. In order to interrupt the engine operation press the MY button on the remote control (in case of the switch, release the button or press the button with the opposite direction). When the blind is fully opened or closed, the motor is automatically stopped by the limit switch. In order to precisely adjust the position of the façade blind slats, use the scroll wheel on the remote control. If you notice that the shutter shield has stopped and the motor is still running, immediately turn off the motor by pressing the MY button on the remote control (in the case of a switch without holding it down, release the button or in the case of a switch with holding it down, press the button in the opposite direction). The motor has a thermal breaker that interrupts operation when the specified temperature is reached. The continuous running time of the motor is about 4 minutes. After this time the motor can switch off until it cools down, i.e. for around 4 to 5 minutes, while the total time needed to cool down the propulsion system is 30 minutes.

Emergency situations:

- 1. In winter, during severe frosts, when opening the window, make sure to not leave the blind tilted. The difference in temperature causes water vapour to settle on the blind and, as a result, to freeze it later. Therefore, before opening the window, the slats of the blind should be completely lifted up.**
- 2. In winter, the slats may become icy and frostbite to the ground. Attempting to open the blind in such a situation may lead to breaking the shield (especially with electric drive). During the period of snowfall or severe frost, before starting up the blind, check whether there is no ice or snow on the window sill or in the guides. If ice is found on the blind, crush the ice gently or wait for it to melt.**
- 3. During expected snowfall or severe frosts it is recommended to switch off the automatic timer and operate the blinds manually, controlling their opening and closing.**
- 4. In case of strong gusts of wind, it is recommended to leave the blind in the position of complete lifting of the slats upwards.**

Maintenance:

The basic principles of product maintenance boil down to cyclical monitoring of the correctness of rolling up and developing of the blind, precision of setting the end positions and cleaning of the available elements of the product. Clean the blind with a soft cloth using commonly available cleaning agents. The use of pressure washers, strong cleaning agents and solvents is prohibited. When cleaning the product, it is not recommended to use sharp tools or cleaning agents causing scratches. When cleaning the product, it is essential to prevent water from getting into the top rail of the product.

Safety rules:

- 1. Do not stay within the working area of the blind while it is being raised or lowered.**
- 2. When using the blinds, pay attention to the condition of the tape and the ladder. Their damage may cause the slats to fall automatically and the blind components to be damaged.**
- 3. In case of any damage or malfunction of a part of the blind, stop using it and call the service centre. The use of a damaged or malfunctioning blind may endanger the health and life of the user.**
- 4. When replacing damaged parts, use only original replacement parts.**
- 5. In the event of a breakdown, it is forbidden to make any temporary repairs.**
- 6. All work related to the repair or replacement of damaged parts of the façade blinds may only be carried out by a trained person. Self-repair attempts may void the warranty.**
- 7. Remote controls should be stored in places that are difficult for children to reach.**
- 8. Do not use the product with visible signs of damage or wear to the electrical wiring.**

Instructions for the adjustment / installation of additional equipment or guidelines for the adjustment of other hardware diagrams are provided individually at the customer's request.

In the Instruction for Use and Maintenance of Joinery, guidelines and diagrams from suppliers were used:

- Schüco,
- Aluprof,
- WinkHaus,
- Portos,
- Dr Hahn,
- Wala.
- Schüring
- Bira